

Canon

DIGISUPER 95

XJ95x8.6B 8.6-820mm 1:1.7



New-generation long-zoom HD field lens delivers enhanced optical performance and extended operational flexibilities



INNOVATION

In TV Optics Since 1958

Toward 100 years anniversary



DIGISUPER 95

XJ95x8.6B 8.6-820mm 1:1.7

The Global expansion of HDTV programming and production has heightened demand for HD lenses designed for live sports and other mobile location applications. Over the past decade, Canon has developed a series of telephoto lenses, including the XJ100x9.3B and XJ86x9.3B/13.5B, to meet the most demanding outside broadcast applications and today these lenses enjoy a high international reputation. To meet end-user's ever-diversifying creative needs, Canon has developed a totally new-generation super-telephoto XJ95x8.6B lens whose overall design is based upon many of Canon's advanced technologies.

The XJ95x's primary advantage is its unprecedented combination of the widest angle of view of any HDTV field lens in the broadcasting industry with an augmented 95x focal range. Its overall optical performance has been significantly elevated and its built-in image stabilization system redesigned to achieve even higher control over picture stability at higher vibration frequencies. This is a lens that offers totally new imaging potential to the global production community involved with HDTV sports and special event coverage.

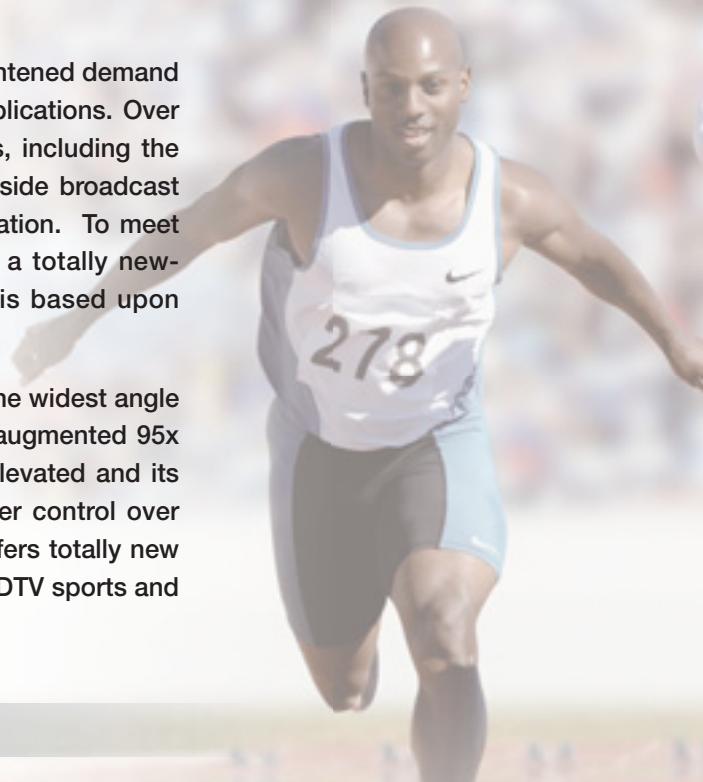

Main Features

From Wide Angle to Telephoto

The XJ95x offers an enormous range of imaging possibilities that are impossible with conventional field lenses, thanks to its 95x zoom ratio and the widest focal length (8.6mm) of any field lens in the industry. With this extensive image-framing latitude, the lens can dramatically capture every possible on-site sensation, from the emotion of an entire crowded stadium to the facial expression of an individual player.

Incomparable Optical Performance

Canon's design and production technologies have been refined through more than 50 years of advanced R&D and extensive experience in broadcast lens development.

The past decade especially has seen dramatic advances in powerful new 3D optical design tools, glass materials, and optical coatings.

Canon's mastery of computer-based 3D optical design techniques and use of the most contemporary optical technologies allow the XJ95x lens to provide a wider angle of view, a higher zoom ratio, and unparalleled overall optical performance.

Canon's proprietary large-diameter aspherical lens technology and exotic new glass materials effectively counter lateral chromatic aberration, monochromatic aberrations, and geometric distortion that have always been the particular challenge of large focal-length ranges. Significant reduction of these aberrations further enhance the resolution and contrast in a manner that contributes to the capture of images having superb picture sharpness across the 16:9 HD image plane.

CAFS (Constant Angle Focusing System)

32-bit CPU calculates and controls the zoom when focusing to counteract "breathing" (phenomena where picture size/ angle of view changes when focusing) and has almost zero zoom effect.



Angle Image of XJ95x (f=8.6mm)
Angle Image of XJ86x (f=9.3mm)



f=8.6mm

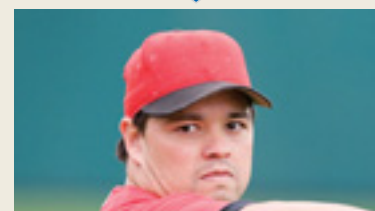

f=820mm

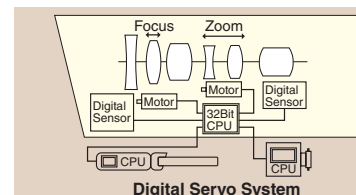



Even More Advanced Image Stabilization System

A persistent problem for telephoto lenses is image blurring at long focal lengths caused by the wind or slight vibrations transmitted through the stadium stand or tower. To minimize this sort of image blurring, the XJ95x comes standard equipped with an improved optical shift-type image stabilizer. When the sensor inside the lens detects a vibration, the compensating optics are shifted at high-speed to instantly deflect the light rays in a direction that cancels out the vibration's effect on the image. The XJ95x's new sensor provides several improvements to Canon's already renowned image-stabilization performance.

Excellent Operability

The XJ95x offers outstanding tracking capability due to its high-resolution encoders to faithfully reproduce the camera operator's intended movements, whether a slow zoom or a preset sequence. The XJ95x, despite its powerful specs, is similar in size and weight to the XJ86x, making it perfectly viable for panning and tilting.

Support for Many Virtual Systems

The XJ95x is equipped with high-performance zoom, focus, and iris encoders. With multiple support for encoder outputs, analog outputs, and serial outputs, the XJ95x can work with many kinds of virtual systems. It easily adapts to existing virtual systems because it comes standard equipped with 20-pin lens interface.



20-pin lens interface

1. Lens when still.

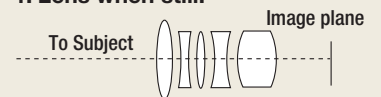

2. Lens when jerked downward.

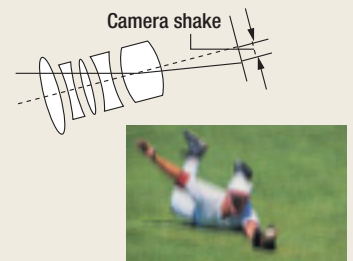

3. Counteraction by IS lens group.

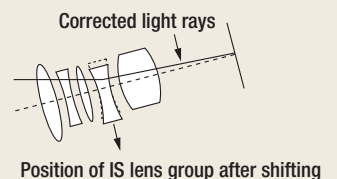

RECOMMENDED LENS SYSTEM

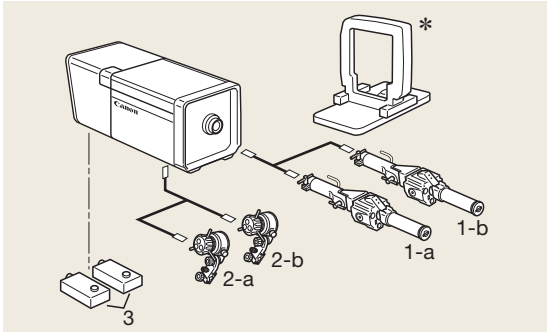

Compatibility of Accessories for DIGISUPER 95

No.	DESCRIPTION	MODEL NAME
1-a	Digital Zoom Demand	ZDJ-P01
1-b	Digital Zoom Demand	ZDJ-D02
2-a	Digital Focus Demand	FDJ-P01
2-b	Digital Focus Demand	FDJ-D02
3	Digital Servo Module	SMJ-E01
—	Protection Filter	PFJ-951
—	IS Switch	SBJ-IS2

* Lens Supporter is necessary for portable camera mounting.

DIMENSIONS

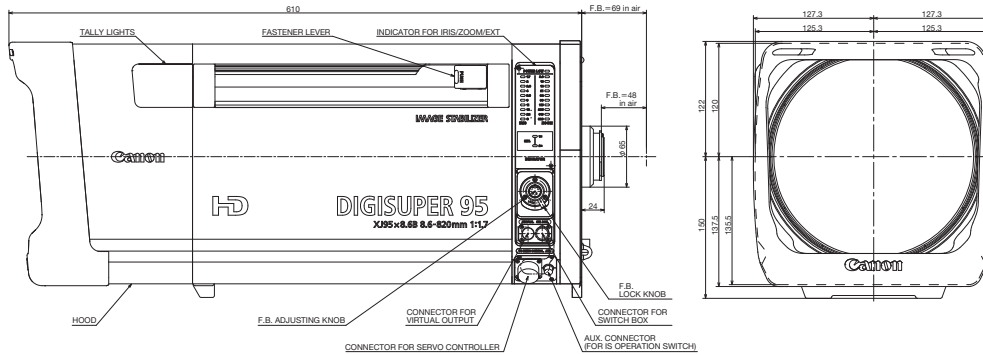

SPECIFICATIONS

DIGISUPER 95	16:9		4:3	
Built-in Extender	1.0x	2.0x	1.0x	2.0x
Zoom Ratio	95x			
Range of Focal Length	8.6 - 820mm	17.2 - 1640mm	8.6 - 820mm	17.2 - 1640mm
Maximum Relative Aperture	1:1.7 at 8.6~340mm 1:4.1 at 820mm	1:3.4 at 17.2~680mm 1:8.2 at 1640mm	1:1.7 at 8.6~340mm 1:4.1 at 820mm	1:3.4 at 17.2~680mm 1:8.2 at 1640mm
Angular Field of View	58.3°×34.9° at 8.6mm 0.67°×0.38° at 820mm	31.2°×17.8° at 17.2mm 0.34°×0.19° at 1640mm	54.2°×42.0° at 8.6mm 0.61°×0.46° at 820mm	28.7°×21.7° at 17.2mm 0.31°×0.23° at 1640mm
Minimum Object Distance (M.O.D.)	3.0m from front lens vertex			
Object Dimensions at M.O.D.	298.1×167.7cm at 8.6mm 3.2×1.8cm at 820mm	149.1×83.9cm at 17.2mm 1.6×0.9cm at 1640mm	274.1×205.6cm at 8.6mm 3.0×2.3cm at 820mm	137.1×102.8cm at 17.2mm 1.5×1.2cm at 1640mm
Approx. Size	W×H×L=250.6×255.5×610.0mm			
Approx. Mass	23.2kg (51.1lbs)			

North & South America Canon U.S.A., Inc.

Imaging Technologies & Communications Group
Broadcast and Communications Sales & Marketing
Division (Headquarters)
65 Challenger Road, Ridgefield Park, NJ 07660
Tel:(201)807-3300/(800)321-4388
Fax:(201)807-3333
Email:bctv@cusa.canon.com
http://www.canonbroadcast.com/

Chicago

100 Park Blvd. Itasca, IL 60143
Tel:(630)250-6236 Fax:(630)250-0399

Atlanta

5625 Oakbrook Pkwy. Norcross, GA 30093
Tel:(770)849-7890 Fax:(770)849-7888

Los Angeles

15955 Alton Parkway Irvine, CA 92618
Tel:(949)753-4330 Fax:(949)753-4337

Dallas

3200 Regent Blvd. Irving, TX 75063
Tel:(972)409-8871 Fax:(972)409-8869

Latin America

Tel:(954)349-6975 Fax:(201)807-3333

Canada

Canon Canada, Inc.

Broadcast and Communications Div.
6390 Dixie Road
Mississauga, Ontario, L5T 1P7, Canada
Tel:(905)795-2012 Fax:(905)795-2140

Europe/Africa/Middle East Canon Europa N.V.

Broadcast and Communications Div.
Bovenkerkerweg 59-61
1185 XB Amstelveen
Tel:+31(0)20-5458905 Fax:+31(0)20-5458203
Email:tvprod@canon-europe.com
http://www.canon-europe.com/tv-products

Australia

Canon Australia Pty. Ltd.
Optical Products Division
1 Thomas Holt Drive, North Ryde, NSW 2113,
Australia
Tel:+61(0)2-9805-2000 Fax:+61(0)2-9805-2444

China

Canon (China) Co., Ltd.

Broadcast Equipment Products
15F Jinbao Building No.89 Jinbao Street
Dongcheng District, Beijing 100005, China
Tel:86-10-8513-9999 Fax:86-10-8513-9128
http://www.canon.com.cn

Asia/Japan

Canon Inc. (Broadcast Equipment Group)

23-10, Kiyohara-Kogyo-Danchi, Utsunomiya-shi,
Tochigi-ken, 321-3298, Japan
Tel:+81(0)28-667-8669 Fax:+81(0)28-667-8672
http://www.canon.com/bctv

Distributed by

Specifications subject to change without notice.

Canon <http://www.canon.com/bctv>